

8-bit Microcontrollers - MCU 7KB Flash 256B RAM 10-bit ADC

28-Pin SPDIP, SOIC, SSOP

Manufacturers	<a href="#">Microchip Technology, Inc</a>
Package/Case	SSOP-28
Product Type	Embedded Processors & Controllers
RoHS	Rohs
Lifecycle	

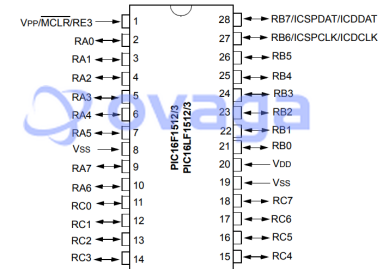

Images are for reference only

Please submit RFQ for PIC16F1513-I/SS or [Email to us: sales@ovaga.com](mailto:sales@ovaga.com) We will contact you in 12 hours.

[RFQ](#)

## General Description

Debug Support• Integrated debug support on Device. No Debug Header is required• Debug and Programming support is available via PICKit™ 3, and MPLAB® ICD 3• For Debug Header Information, please refer to DS51292

## Features

Enhanced Mid-range Core with 49 Instruction, 16 Stack Levels

Flash Program Memory with self read/write capability

High Endurance Flash Memory (HEF)

128 B of Non-volatile Data Storage

Internal 16MHz oscillator

MI2C, SPI, EUSART w/auto baud

Two CCP (Capture Compare PWM) Module

17 Channel 10-bit ADC with Advanced Controls

25mA Source/Sink current I/O

Two 8-bit Timers (TMR0/TMR2)

One 16-bit Timer (TMR1)

Extended Watchdog Timer (WDT)

Enhanced Power-On/Off-Reset

Programmable Ultra Low-Power Brown-Out Reset (ULPBOR)

In Circuit Serial Programming (ICSP)

In-Circuit Debug

Wide Operation Voltage Variant 'F' (2.3V – 5.5V)

eXtreme Low Power (XLP) 'LF' Variant (1.8V – 3.6V)

## 28-Pin SPDIP, SOIC, SSOP

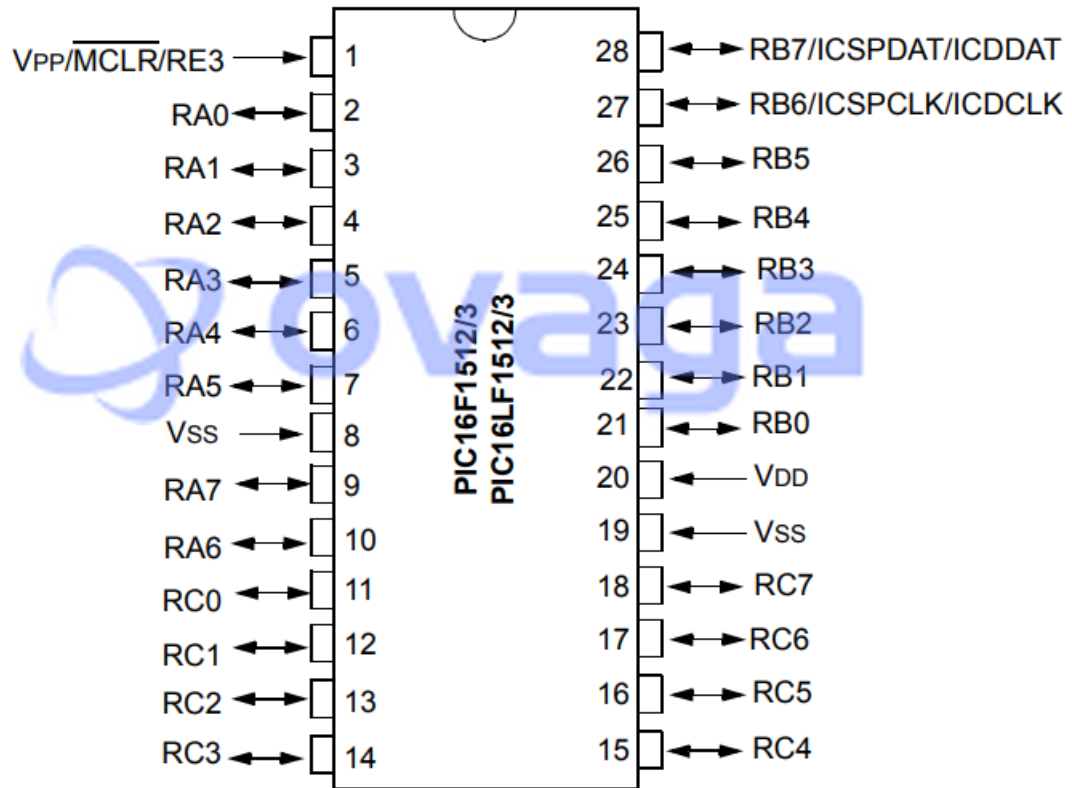





[PIC18F2620-I/SO](#)

Microchip Technology, Inc  
SOIC-28



[PIC18F97J60T-I/PT](#)

Microchip Technology, Inc  
TQFP-100